

# INSTRUCTIONS FOR INSTALLATION AND USE OF SDU.

## WIRING DIAGRAM

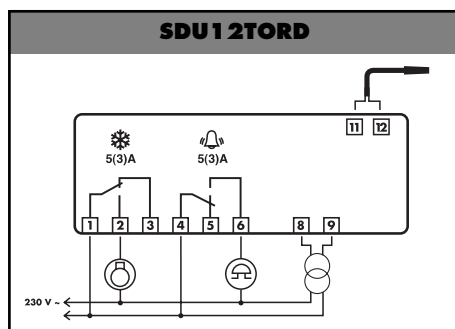
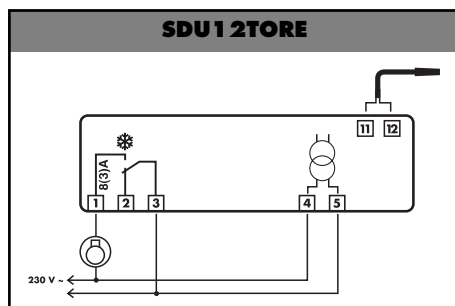

## TECHNICAL DATA

### SDU 1 12/SDU 1 2

Dimensions	77x35x77 mm
Operating temp.	-10°...+50°C
Range	-19°...+99°C
Resolution	1°C
Input	PTC 1000
Relay power rating	refer to data on unit
Connections	screw terminal blocks, Ø 2 mm <sup>2</sup>
Supply voltage	refer to data on unit
Consumption	2VA
Front panel protection	IP40; opt. IP54
Enclosure inflammability	fire-retardant

We reserve the right to make modifications without prior notice.

**lae**<sup>®</sup>  
**ELECTRONIC**

VIA PADOVA, 25  
31046 ODERZO /TV /ITALY  
TEL. 0422 815320 - 815303  
TELEFAX 0422 814073  
www.lae-electronic.com  
E-mail: info@lae-electronic.com

**SDU** is a controller allowing temperature and defrost control of static and ventilated refrigerators.

To get best performance, before installing and using it, read this instruction sheet carefully.

## 1 INSTALLATION

**1a** The instrument is secured to the panel from the rear, after making a 29x71 mm hole, by means of the suitable brackets, exerting correct strength. If using the rubber gasket ("S" version), this must be interposed between the panel and the instrument bezel, checking the perfect adhesion carefully.

**1b** For proper functioning the instrument needs an ambient temperature between -10°...+50°C and 15%...80% relative Humidity. To improve protection of the probe against electro-magnetic interference, which might compromise its function, place its cable and the controller away from power lines.

**1c** Probe, power supply and outputs must be connected strictly following the diagram on the enclosure, where the maximum switching powers and supply voltage are indicated, too.

The probe screen must not be connected to any other leads. If the external transformer is needed, the instrument must be powered by the suitable transformer supplied by LAE (mod. TR...).

**1d** Should the instrument be recalibrated, in consequence of probe replacement or considerable cable lengthening, then proceed as follows: use an accurate thermometer, make sure that the two probes are at the same temperature, immersing them in a liquid if necessary. By means of a screwdriver turn the trimmer located close to the inscription "0°ADJ."

### CAUTION!

- *If the relays switch large loads frequently, we suggest you contact us to obtain information about the relay contact life.*
- *Where delicate or valuable products have to be maintained in special conditions, we recommend not to use the same instrument for both control and limit functions.*

## 2 FUNCTIONING DESCRIPTION

After having installed the instrument and carried out the connections, power the instrument.

**2a** The setpoint, which represents the On/Off switching temperature of the cooler, is displayed by pushing **1**; to change its value within the limits programmed in SETUP, while **1** is kept pressed, push **2** to increase or **3** to decrease. When **1** is released, the new programmed value is stored.

**2b** In order to start manual defrost, keep keys **2** and **3** pressed for 3 sec.; to stop it, follow the same procedure.

**2c** When the alarm is entered, as a result of the temperature staying above the higher alarm threshold or below the lower one for longer than the delay (see SETUP), the indication "AL" is alternated with the actual temperature; if the unit is fitted with a buzzer and/or alarm relay, this latter is switched on. The alarm condition is stored, therefore the alarm signalings continue regardless of the temperature. By pressing any of the keys the buzzer is muted the relay is switched off and,

if the temperature has returned within the setpoint limits, the indication "AL" disappears; as long as the alarm condition exists, every 30 min. the buzzer/relay is switched On for 1 min.

During defrost the high alarm is inhibited.

**2d** The On status of the output and defrost phase are shown on display through the lighting up of the LED's placed close to the relative symbols.

**2e** As a result of probe failure, its connection breakdown or overrange, "PF" is displayed and the buzzer/relay is switched on immediately, which can be muted by pressing any of the pushbuttons. The compressor output will operate according to the duty cycle programmed in SETUP.

**2f** It's possible to simulate the behaviour of a thermal mass inside the refrigerator; this allows to avoid rapid fluctuations of the displayed temperature, resulting for example from door opening or defrost, but also to reduce hunting due to temperature control. The fluctuation speed of the displayed temperature depends on the value assigned to "Si"; it's however possible to display the instantaneous temperature as long as the key **2** is kept pressed.

## 3 SETUP

**SDU** configuration is made through programming of the control parameters; access to it is possible through a sequence of operations preventing accidental activation.

**3a** Keep keys **2**+**1**+**2** pressed for 3 sec., exactly in this sequence.

To select the desired parameter press key **2**. To show its value press **1** and if necessary change it via **2** or **3**; store it with **1**. No key activation within 10 sec. causes the controller to switch over to the basic functioning. It's also possible to select a specific parameter and change its value by following the diagram attached.

**3b** Parameter description:

**SL:** minimum setpoint limit (-19°...+99°C).

**Sh:** maximum setpoint limit (SL...+99°C).

**hY:** hysteresis which, added to the Set Point, determines the on switching threshold of the cooler relay (+01°...+10°K). When you have to maintain a very small hysteresis hY, we recommend to program a suitable value for **Pc** to ensure a long life to relay/contactors and compressor.

**Pc:** it represents the minimum Off time of the output. It's the minimum time between Off and On switching of the cooler regardless of the temperature measured by the probe (00...10 minutes).

**Po:** it allows to programme an offset between the measured and the displayed temperature (-19°...+19°K).

**PF:** in case of probe failure, defrosts are suspended and the cooler run is not controlled by setpoint but it is determined by PF which represents the duty cycle (00...10\*10%), that is the On time and the Off time within a 10 min. cycle. For ex.: 06= 6 min. On, 4 min. Off. This value should be calculated keeping into consideration the normal cooler duty cycle. This function allows to avoid damage to the goods when the actual temperature can not be measured as a result of a probe failure. The minimum intervention time, during which the operator can not interrupt the cycle, has 10 min. duration.

**dt:** the interval between a defrost and the

next (01...24 hours); defrost duration is not included. In case of a power failure, when the power comes on again, the defrost timer re-starts the counting from the point where it was interrupted, with ±30 min. approximation.

**dd:** defrost duration, i.e. the cooler off cycle (01...99 minutes).

**do:** if set at 01, it allows defrost optimisation, by considering as defrosts cooler pauses of duration equal or greater than dd. For ex. dd= 20 min. If the cooler remains off for 20 min. without interruption, the timer will be reset and as a consequence the start of the next defrost will be postponed. If do= 00, optimisation is excluded.

**df:** it allows to select the display indication during defrost. If df=00, then the temperature measured by the probe continues to be displayed; if -1, the display shows "df" until the setpoint is reached again. If df=01...99 min., "df" is displayed all through defrost and after until the time programmed has elapsed, unless the setpoint is achieved before.

**AL:** lower alarm threshold (-19°C...SL).

**Ah:** higher alarm threshold (Sh...+99°C).

**Ad:** it allows to: exclude the alarm function (-1); programme a delay between the detection of the alarm condition and its signalling (00...99 minutes).

**Si:** by programming a value between 01 and 99 you establish the thermal mass to be simulated, if 00 is selected the instantaneous probe temperature is displayed; the greater the programmed value, the greater the resulting display slow down will be. It is important to note that temperature and alarm control are based on the instantaneous air temperature and are therefore not influenced by "Si" values.

**YY:** 01 DO NOT CHANGE. In case the value 00 is selected by mistake, after exit from the SETUP it's not possible to have access to it again by following the sequence described at point 3a.

Act as follows: switch off the unit; while the three pushbuttons are kept pressed, turn on the unit again.

## WARRANTY

LAE electronic Srl warrant that their products are free of any defects in workmanship and materials for a period of 1 (one) year from date of production shown on the enclosure. LAE electronic Srl shall only repair or replace those products of which defects are due to LAE electronic Srl and recognised by their technicians. LAE electronic Srl are not liable for damages resulting from malfunctions of the products.

Defects due to exceptional operating conditions, misapplication and/or tampering will void the warranty.

All transport charges for returning the product to the manufacturer, after prior authorisation by LAE electronic Srl, and for the return to the purchaser are always for the account of the purchaser.

# SDU

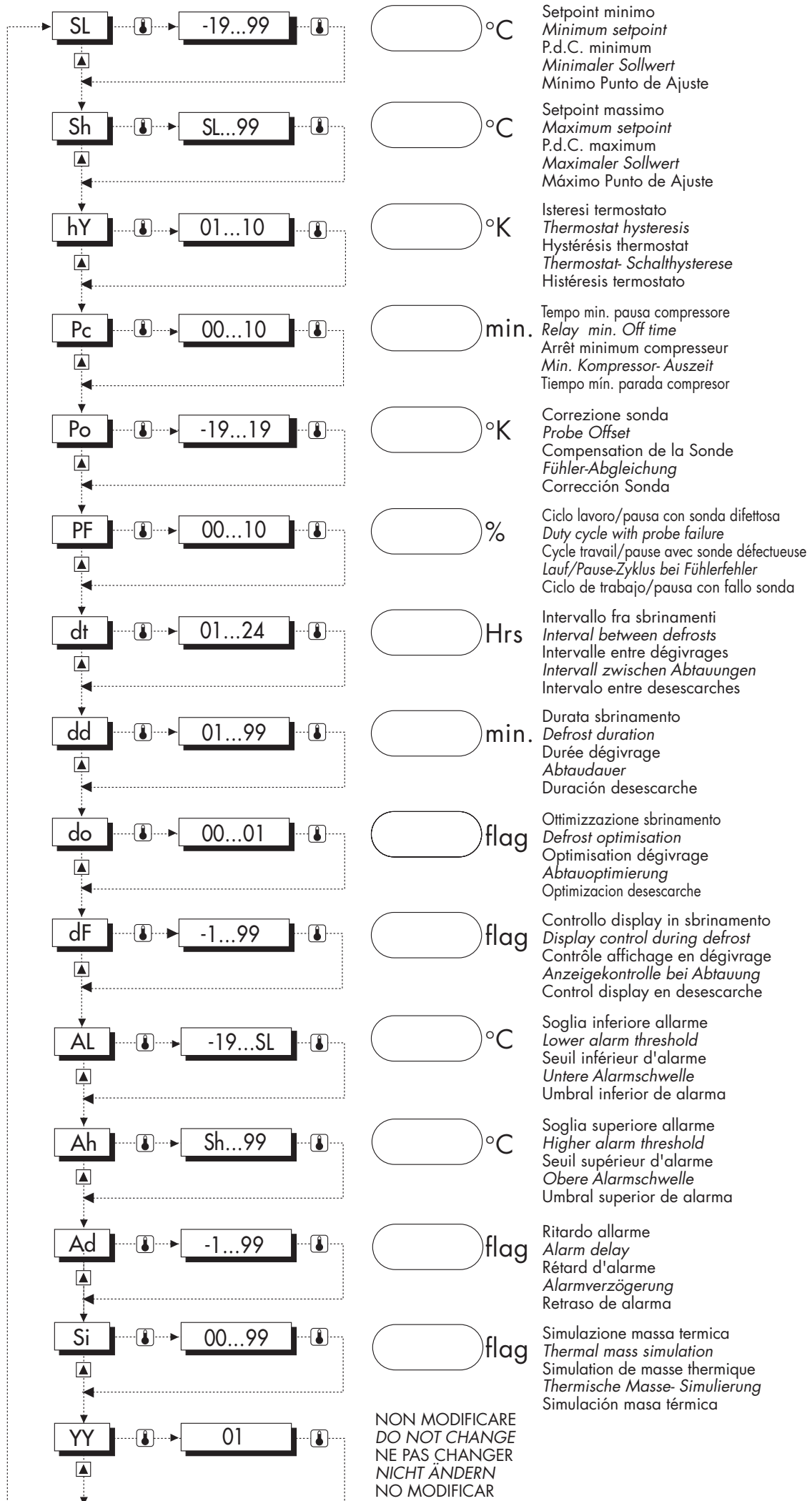

NON MODIFICARE  
 DO NOT CHANGE  
 NE PAS CHANGER  
 NICHT ÄNDERN  
 NO MODIFICAR